

### ⚡ Specifications

#### Nominal Voltage(V)

12V

#### Nominal Capacity

20 hour rate	(2A	to	10.50V)	40Ah
10 hour rate	(3.8A	to	10.50V)	38Ah
5 hour rate	(6.8A	to	10.20V)	34Ah
5 min rate	(140A	to	9.60V)	11.67Ah
1 C	(40A	to	9.60V)	21.33Ah
3 C	(120A	to	9.60V)	14Ah

#### Weight

Approx. 12.6kg(27.7Lbs.)

#### Internal Resistance (at 1KHz)

Approx. 8.5 mΩ

#### Maximum Discharge Current for

5 seconds: 600A

#### Charging Methods at 25°C(77°F)

Maximum Charging Current :	12A
Standby use:	
Float Charging Voltage	13.5 to 13.8V
Coefficient -3.0mV/°C/cell	

#### Operating Temperature Range

Charge	-15°C(5°F)	to	40°C(104°F)
Discharge	-15°C(5°F)	to	50°C(122°F)
Storage	-15°C(5°F)	to	40°C(104°F)

#### Charge Retention (shelf life) at 20°C(68°F)

1 month	97%
3 month	92%
6 month	85%

#### Case Material

ABS UL94 HB  
Option: Flammability resistance of (UL94 V-0)

#### Design Life

EUROBAT(20°C): 3-5 YEARS STANDARD COMMERCIAL

#### Terminal

F4



### ⚡ Dimensions

#### Length (L)

198 ± 1 (7.80 ± 0.08 / 0.04)

#### Width (W)

166 ± 1 (6.54 ± 0.08 / 0.04)

#### Height (H)

171 ± 1 (6.73 ± 0.08 / 0.04)

#### Overall Height (HT)

171 ± 1 (6.73 ± 0.08 / 0.04)

mm(inch)

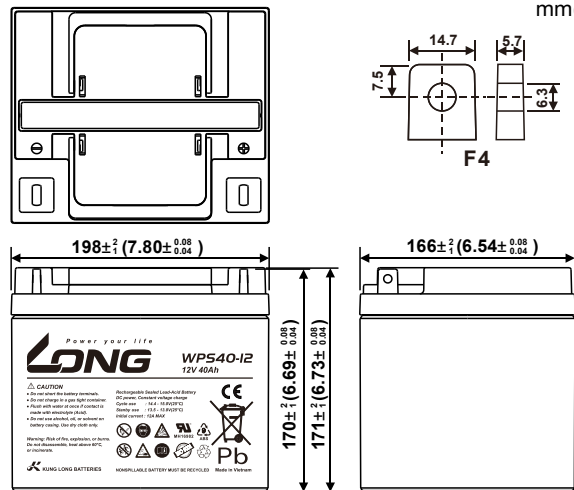

(V) FOR 12V BATTERY Discharge Time VS. Discharge Current (25°C)

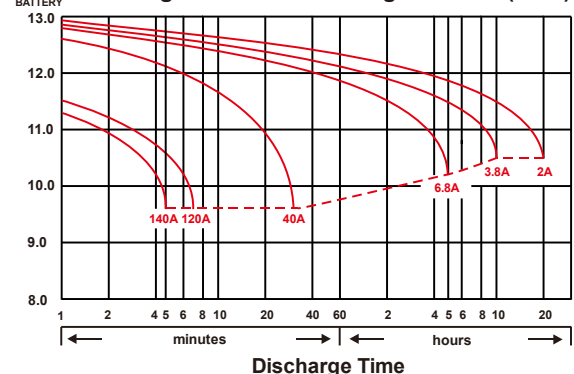

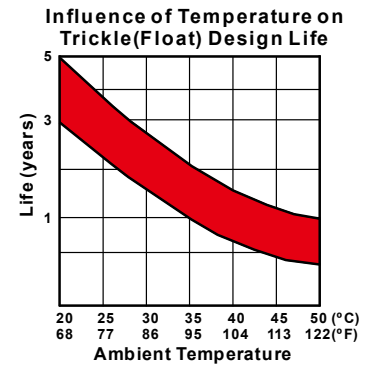
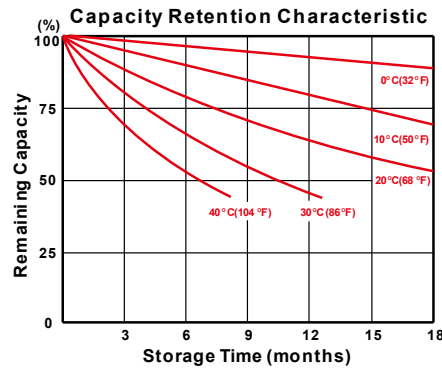
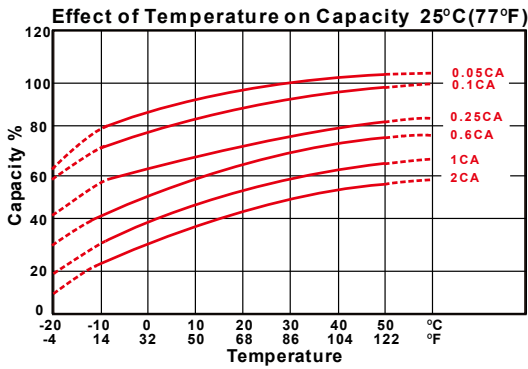

### - PERFORMANCE DATA

#### Discharge Rates in Watts to Various End Voltages at 25°C(77°F)

End Voltage		1.85V	1.80V	1.75V	1.70V	1.67V	1.65V	1.60V
10	min	113	133	149	159	163	163	166
15	min	101	113	123	128	130	131	132
30	min	70.7	73.8	75.8	76.5	76.7	77.0	77.3
45	min	56.5	59.2	62.5	62.7	63.0	63.2	63.3
60	min	43.8	45.8	46.8	47.3	47.5	47.7	47.8
90	min	33.7	35.0	35.7	36.0	36.2	36.5	36.7
120	min	27.7	28.7	29.2	29.5	29.7	29.8	30.0
180	min	19.2	19.8	20.2	20.3	20.5	20.5	20.7
240	min	15.4	15.9	16.1	16.2	16.3	16.4	16.4
300	min	13.2	13.6	13.7	13.8	13.9	13.9	14.0
480	min	9.03	9.22	9.37	9.47	9.52	9.55	9.63
600	min	7.80	7.95	8.05	8.13	8.18	8.22	8.27
1200	min	3.92	4.00	4.03	4.07	4.08	4.08	4.10

#### - Discharge Rates in Amperes to Various End Voltages at 25°C(77°F)

End Voltage		1.85V	1.80V	1.75V	1.70V	1.67V	1.65V	1.60V
10	min	66.4	77.0	86.2	92.3	94.2	94.4	96.2
15	min	55.1	61.6	66.8	69.6	70.6	71.2	72.2
30	min	35.9	37.5	38.5	38.9	39.0	39.1	39.2
45	min	28.7	30.1	31.5	31.9	32.0	32.1	32.2
60	min	22.5	23.5	24.0	24.3	24.4	24.5	24.6
90	min	17.2	17.9	18.2	18.4	18.5	18.6	18.7
120	min	13.9	14.4	14.7	14.8	14.9	15.0	15.1
180	min	9.63	10.0	10.1	10.2	10.2	10.3	10.3
240	min	7.70	7.94	8.03	8.09	8.13	8.15	8.20
300	min	6.57	6.76	6.82	6.87	6.90	6.93	6.97
480	min	4.49	4.58	4.65	4.70	4.73	4.75	4.79
600	min	3.87	3.95	4.00	4.04	4.06	4.08	4.10
1200	min	1.94	1.98	2.00	2.02	2.02	2.03	2.04

All data on the spec. sheet is an average value:

The tolerance range :  $X < 6\text{min}$ (+15%~-15%),  $6\text{min} \leq X < 10\text{min}$ (+12%~-12%),  $10\text{min} \leq X < 60\text{min}$ (+8%~-8%),  $X \geq 60\text{min}$ (+5%~-5%)

230226-1A-T