

⚡ Specifications

Nominal Voltage(V)

12V

Nominal Power

15 mins rate: 500W/cell to 1.67V/cell

Nominal Capacity

20 hour rate	(7.5A to 10.50V)	150Ah
10 hour rate	(14.25A to 10.50V)	142.5Ah
8 hour rate	(17.25A to 10.50V)	138Ah
5 hour rate	(25.5A to 10.20V)	127.5Ah

Weight

Approx. 50.5kg(111Lbs.)

Internal Resistance (at 1KHz)

Approx. 4.5 mΩ

Maximum Discharge Current for

5 seconds: 1500A

Short Circuit Current (A) IEC 60896-21-22

2670A

Charging Methods at 25°C(77°F)

Maximum Charging Current :	45A
Boost Charging Voltage	14.1 to 14.4V
Boost Charge Time	8-9Hr
Float Charging Voltage	13.5 to 13.65V
Coefficient	-3.0mV/°C/cell

Operating Temperature Range

Charge	-15°C(5°F)	to	40°C(104°F)
Discharge	-15°C(5°F)	to	50°C(122°F)
Storage	-15°C(5°F)	to	40°C(104°F)

Charge Retention (shelf life) at 20°C(68°F)

1 month	98%
3 month	96%
6 month	94%

Case Material

ABS UL94 HB

Option: Flammability resistance of (UL94 V-0)

Battery Construction

Component	Positive Plate	Negative plate	Safety valve	Terminal	Separator	Electrolyte
Raw material	Lead dioxide	Lead	Rubber	Copper	AGM	Sulfuric acid



⚡ Dimensions

Length (L)	550±3 (21.65±0.12)
Width (W)	110±3 (4.33±0.12)
Height (H)	288±3 (11.34±0.12)
Overall Height (HT)	288±3 (11.34±0.12)

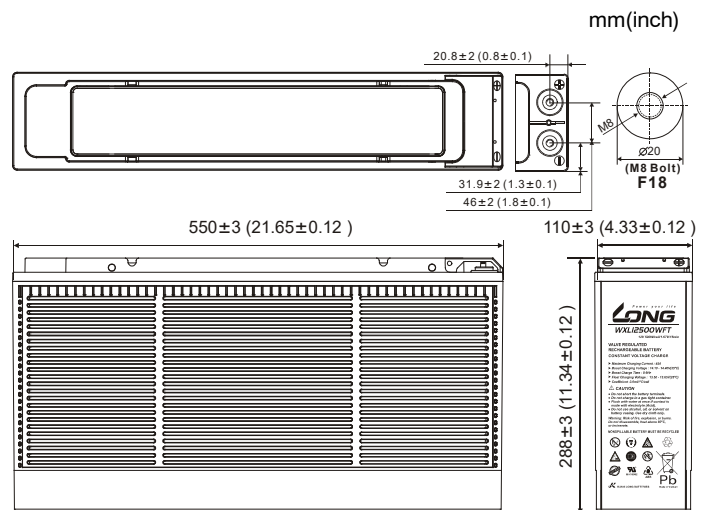

Terminal

F18

Recommended torque value M8: 12 N-m (122 kgf-cm)

Maximum allowable torque value M8: 20 N-m (204 kgf-cm)

Design Life

EUROBAT(20°C) : > 12 YEARS VERY LONG LIFE

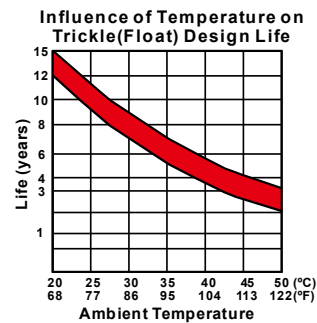
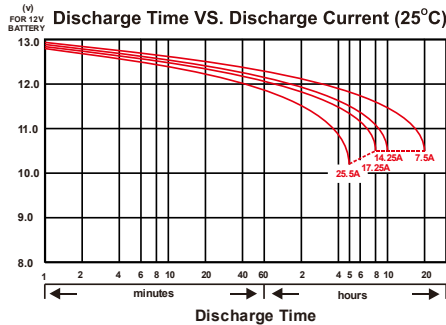
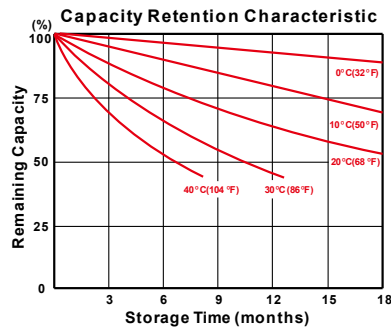
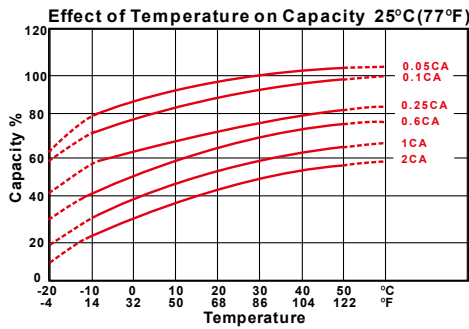

- PERFORMANCE DATA

Discharge Rates in Watts to Various End Voltages at 25°C(77°F)

End Voltage		1.85V	1.80V	1.75V	1.70V	1.67V	1.65V	1.60V
Time								
5	min	462	523	580	613	643	680	710
10	min	380	450	505	525	542	557	567
15	min	330	405	456	489	499	509	520
30	min	197	241	272	291	297	303	310
60	min	164	175	182	186	187	188	189
120	min	88.3	93.2	95.8	98.0	98.8	99.7	101
180	min	70.2	73.8	76.5	78.5	79.2	80.0	80.8
240	min	57.5	60.3	62.2	63.7	64.2	64.8	65.5
300	min	48.8	51.3	53.2	54.3	54.7	55.2	55.7
480	min	35.7	36.7	38.2	39.2	39.5	39.8	40.2
600	min	29.3	31.2	31.8	32.3	32.5	32.7	32.8
1200	min	15.0	15.8	16.4	16.8	17.0	17.2	17.3

Discharge Rates in Amperes to Various End Voltages at 25°C(77°F)

End Voltage		1.85V	1.80V	1.75V	1.70V	1.67V	1.65V	1.60V
Time								
5	min	247	272	334	363	390	415	437
10	min	210	250	282	302	319	334	349
15	min	193	234	261	280	285	291	298
30	min	107	132	148	159	162	165	169
60	min	82.7	89.9	92.7	94.8	95.6	96.4	97.5
120	min	43.7	49.6	52.1	53.9	54.6	55.4	56.4
180	min	32.4	37.2	39.1	40.5	41.0	41.6	42.3
240	min	27.4	30.1	31.4	32.4	32.7	33.1	33.5
300	min	23.7	25.6	26.6	27.4	27.6	27.9	28.1
480	min	16.6	17.5	18.0	18.3	18.4	18.6	18.7
600	min	14.4	15.0	15.2	15.4	15.6	15.8	16.0
1200	min	7.25	7.50	7.78	7.82	7.90	7.97	8.02

All data on the spec. sheet is an average value:

The tolerance range : $X < 6\text{min}$ (+15%~-15%), $6\text{min} \leq X < 10\text{min}$ (+12%~-12%), $10\text{min} \leq X < 60\text{min}$ (+8%~-8%), $X \geq 60\text{min}$ (+5%~-5%)

250226-1C